

Scientific Misconduct & Research Integrity

Historical Background, Current Global Challenges and Initiatives

Nicholas H. Steneck, PhD
University of Michigan

First Brazilian Meeting on Research
Integrity, Science and Publication
Ethics

December 10, 2010

Overview: Ask & answer 4 questions

1. How *should* researchers behave?
2. How *do* researchers behave?
3. How *have* researchers and research institutions responded to misbehavior in research
4. How *should* researchers and research institutions respond to misbehavior in research?

Brazilian Science

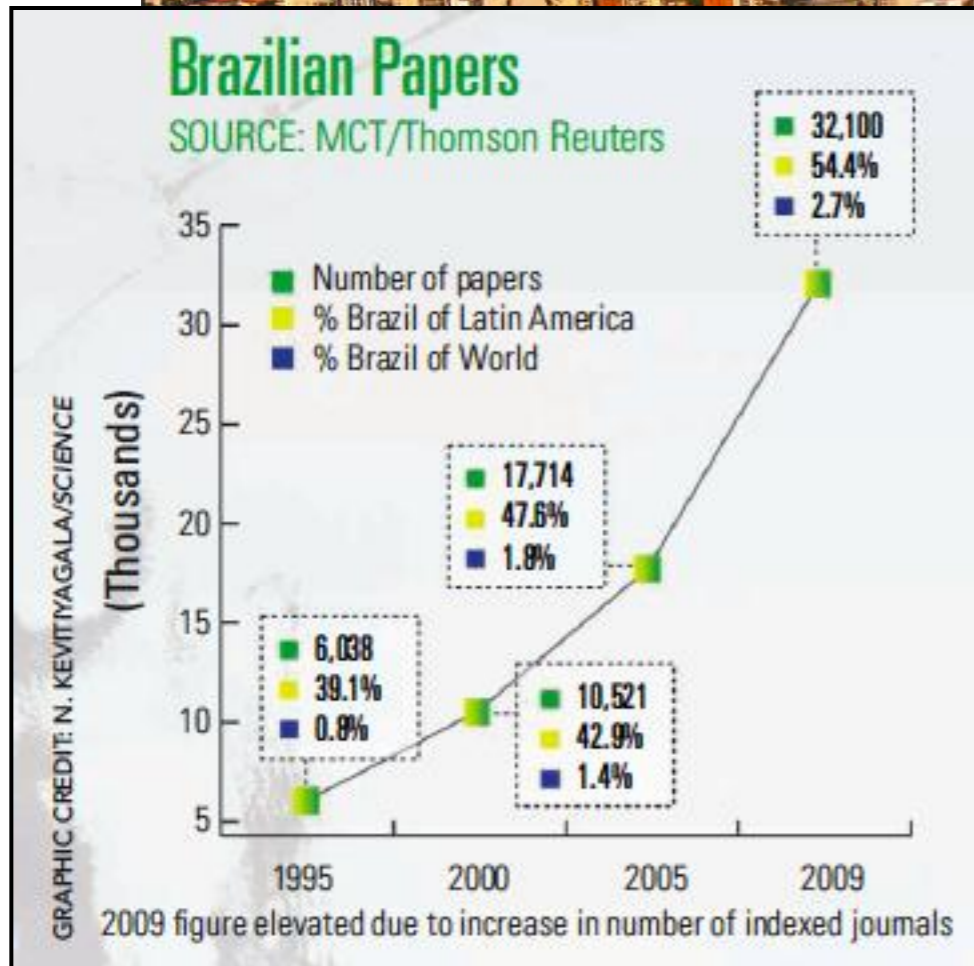
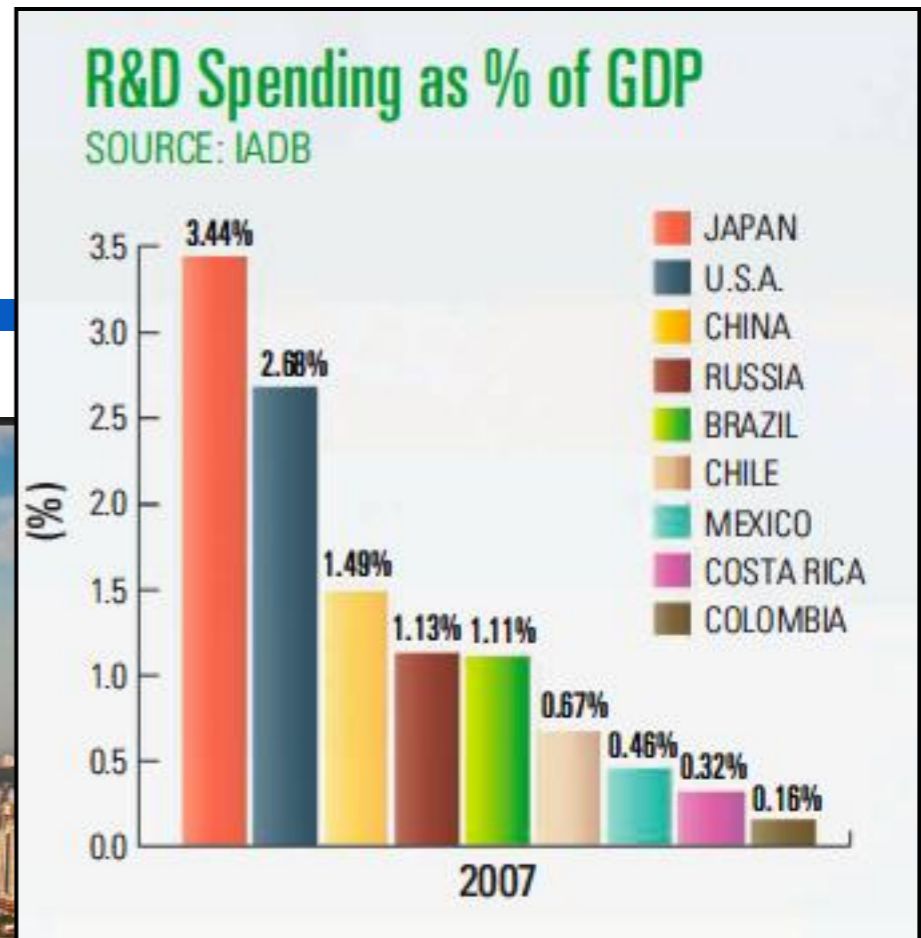

Brazilian Science: Riding a Gusher

A fast-growing economy and oil discoveries are propelling Brazil's research to new heights. But scientific leaders must overcome a weak education system and a low-impact track record

Research - Integrity

Activity

Judgement

Conduct

Character

Publish

Behavior

Service

Responsibility



Q1. How should researchers behave?



➤ Principles:



www.singaporestatement.org

- ✓ Honesty in all aspects of research
- ✓ Accountability in the conduct of research
- ✓ Professional courtesy and fairness in working with others
- ✓ Good stewardship of research on behalf of others

Responsibilities (Singapore Statement)

1. Integrity
2. Adherence to Regulations
3. Research Methods
4. Research Records
5. Research Findings
6. Authorship
7. Publication Acknowledgement
8. Peer Review
9. Conflict of Interest
10. Public Communication
11. Reporting Irresponsible Research Practices
12. Responding to Irresponsible Research Practices
13. Research Environments
14. Societal Considerations

The value and benefits of research are vitally dependent on the integrity of research. While there can be and are national and disciplinary differences in the way research is organized and conducted, there are also principles and professional responsibilities that are fundamental to the integrity of research wherever it is undertaken.



_____ Yes?

_____ No?

Q2. How do Researchers Behave?

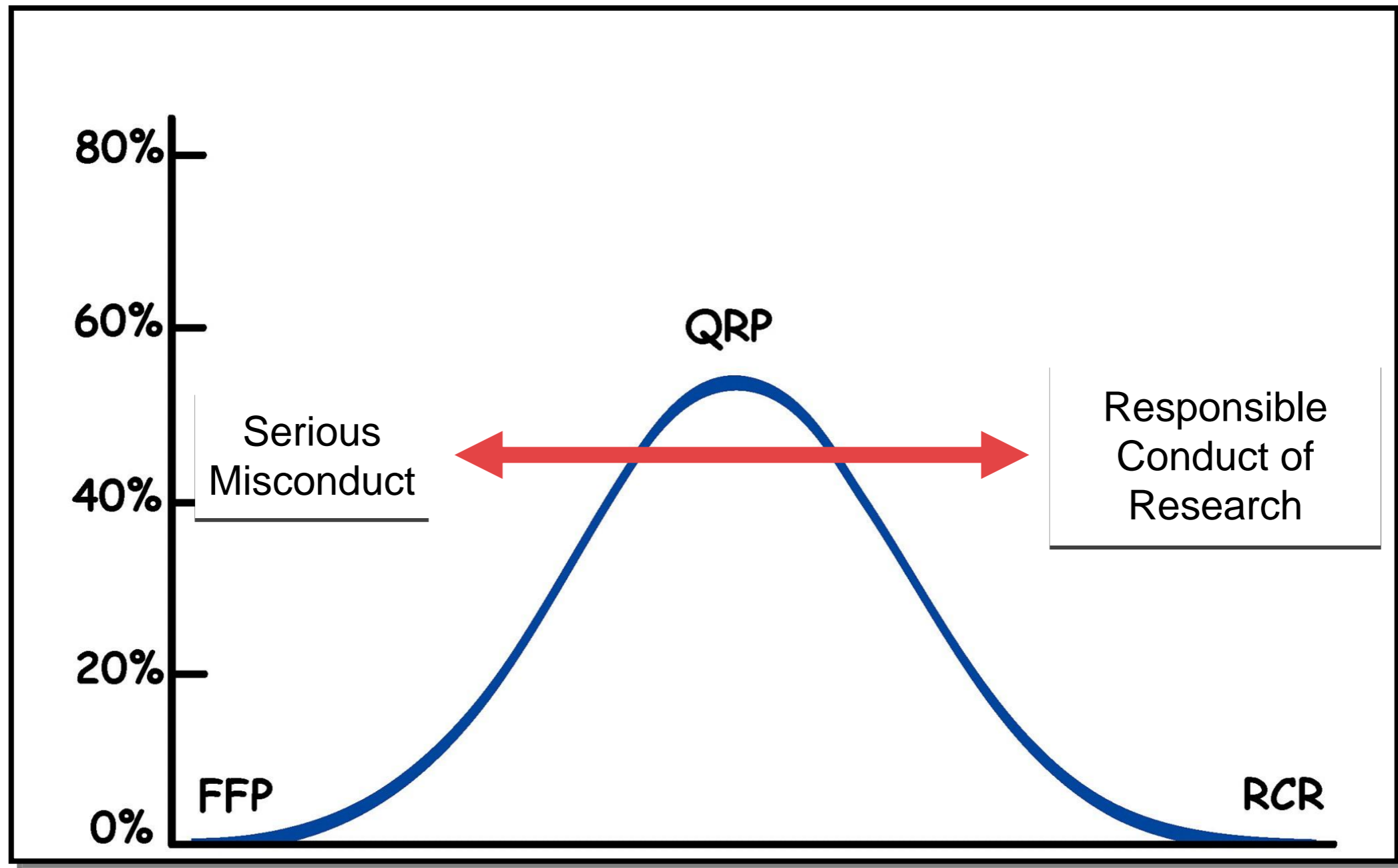

R #1. Integrity

Researchers should take responsibility for the trustworthiness of their research.



Schoen



Sudbo



Hwang

- Estimate: 1 in 100 to 1 in 1,000 researchers engage in serious misconduct

R #2. Adherence to Regulations

Researchers should be aware of and adhere to regulations and policies related to research.

➤ Policies

- ✓ Human subject
 - ✓ Animal subject
 - ✓ Conflict of interest
 - ✓ Data sharing
 - ✓ Export control
 - ✓ Workplace safety
- Frequency of violations: 1%-10%



3. Research Methods:

Researchers should employ appropriate research methods, base conclusions on critical analysis of the evidence and report findings and interpretations fully and objectively.

Behaviors that happen and impact research record (Delphi Study)	
Over interpretation of “significant” findings in small trials	83%
Selective reporting based on p-values	80%
Selective reporting of outcomes in the abstract	76%
Subgroup analyses done without interaction tests	75%
Negative or detrimental studies not published	68%
Putting undue stress on results from subgroup analysis	68%
Inappropriate subgroup analyses	64%
Selective reporting of (i) subgroups (ii) outcomes (iii) time points	64%
Selective reporting of positive results	60%
Omission of adverse events data	60%
Failure to report results or long delay in reporting	60%
Post-hoc analysis not admitted	59%
Giving incomplete information about analyses with non significant results	56%

4. Research Records:

Researchers should keep clear, accurate records of all research in ways that will allow verification and replication of their work by others.

- Requirements:
 - ✓ Bound notebook or electronic record authentication
 - ✓ Signed and dated
 - ✓ Reproducible detail
- In practice, 20-40% do not follow best practices

5. Research Findings:

Researchers should share data and findings openly and promptly, as soon as they have had an opportunity to establish priority and ownership claims.

- Common practices:
 - ✓ Delay sharing to slow work of competitors
 - ✓ Deny access to crucial information
 - ✓ Provide incomplete information in publications
- Frequency: 10% and above
- Slows progress of research

6. Authorship:

Researchers should take responsibility for their contributions to all publications, funding applications, reports and other representations of their research. Lists of authors should include all those and only those who meet applicable authorship criteria.

- Common practices in research publications:
 - ✓ Honorary authors – do not deserve authorship
 - ✓ Ghost authors – wrote paper, not listed
- Requirement for authorship:
 1. Participate in design, contribute significant ideas
 2. Collect and interpret data
 3. Draft and take responsibility for publication
- Violations in some journals over 50%

7. Publication Acknowledgement:

Researchers should acknowledge in publications the names and roles of those who made significant contributions to the research, including writers, funders, sponsors, and others, but do not meet authorship criteria.

- Common practices:
 - ✓ Plagiarism - using someone else's word, data, ideas or work without credit
 - ✓ Self-plagiarism – using your own prior writing without acknowledging
- Frequency – no firm data; often blamed on new research powers, e.g. China, India,

8. Peer Review:

Researchers should provide fair, prompt and rigorous evaluations and respect confidentiality when reviewing others' work.

- Common practices:
 - ✓ Delay review to slow work of competitors
 - ✓ Have students do reviews without permission
 - ✓ Use information from reviews to advance own work
- Evidence, reviews biased by: a) field, b) method, c) country and d) institution

9. Conflict of Interest:

Researchers should disclose financial and other conflicts of interest that could compromise the trustworthiness of their work in research proposals, publications and public communications as well as in all review activities.

- Common practices:
 - ✓ Researchers do not declare conflicts of interest
 - ✓ Journals do not enforce conflict of interest policies
- Impact of conflict of interest:
 - ✓ Funding influences results reported
 - Two researchers study same compound
 - Researchers funded by companies that own a compound report more favorable results than those not funded by the company

10. Public Communication:

Researchers should limit professional comments to their recognized expertise when engaged in public discussions about the application and importance of research findings and clearly distinguish professional comments from opinions based on personal views.

- Researchers advocate for:
 - ✓ Human rights
 - ✓ Environmental protection / about global warming
 - ✓ Medicines and public health
 - ✓ More research funding
- Not always based on the expertise
- No clear rules for communication & advocacy

11. Reporting Irresponsible Research Practices:

Researchers should report to the appropriate authorities any suspected research misconduct, including fabrication, falsification or plagiarism, and other irresponsible research practices that undermine the trustworthiness of research, such as carelessness, improperly listing authors, failing to report conflicting data, or the use of misleading analytical methods.

- Responsibility is based on self-regulation
- Researchers are not good at self-regulation
 - ✓ 30%-40% aware of misconduct do not report
 - ✓ Staff in key positions (clinical trial coordinators) reluctant to report
- Research misconduct is under-reported

12. Responding to Irresponsible Practices

Research institutions, as well as journals, professional organizations and agencies that have commitments to research, should have procedures for responding to allegations of misconduct and other irresponsible research practices and for protecting those who report such behavior in good faith. When misconduct or other irresponsible research practice is confirmed, appropriate actions should be taken promptly, including correcting the research record.

- Practices vary from country to country
 - ✓ US, government-funded must have policies
 - ✓ Many countries have no central policies
- OECD (2007 / 2009)
 - ✓ Every country should have misconduct policies
 - ✓ International collaborations should have misconduct agreements

13. Research Environments:

Research institutions should create and sustain environments that encourage integrity through education, clear policies, and reasonable standards for advancement, while fostering work environments that support research integrity.

- US requires RCR training
- Growing global interest in RCR training growing

- More to follow.....

14. Societal Considerations:

Researchers and research institutions should recognize that they have an ethical obligation to weigh societal benefits against risks inherent in their work.

- Most controversial responsibility in Statement
 - ✓ Wide-spread agreement that social responsibility is important
 - ✓ Some questioned need in a statement on integrity
- Makes sense in principle
- Difficult to put into practice since views on social responsibility vary
- Examples: climate change / stem cells

How researchers behave

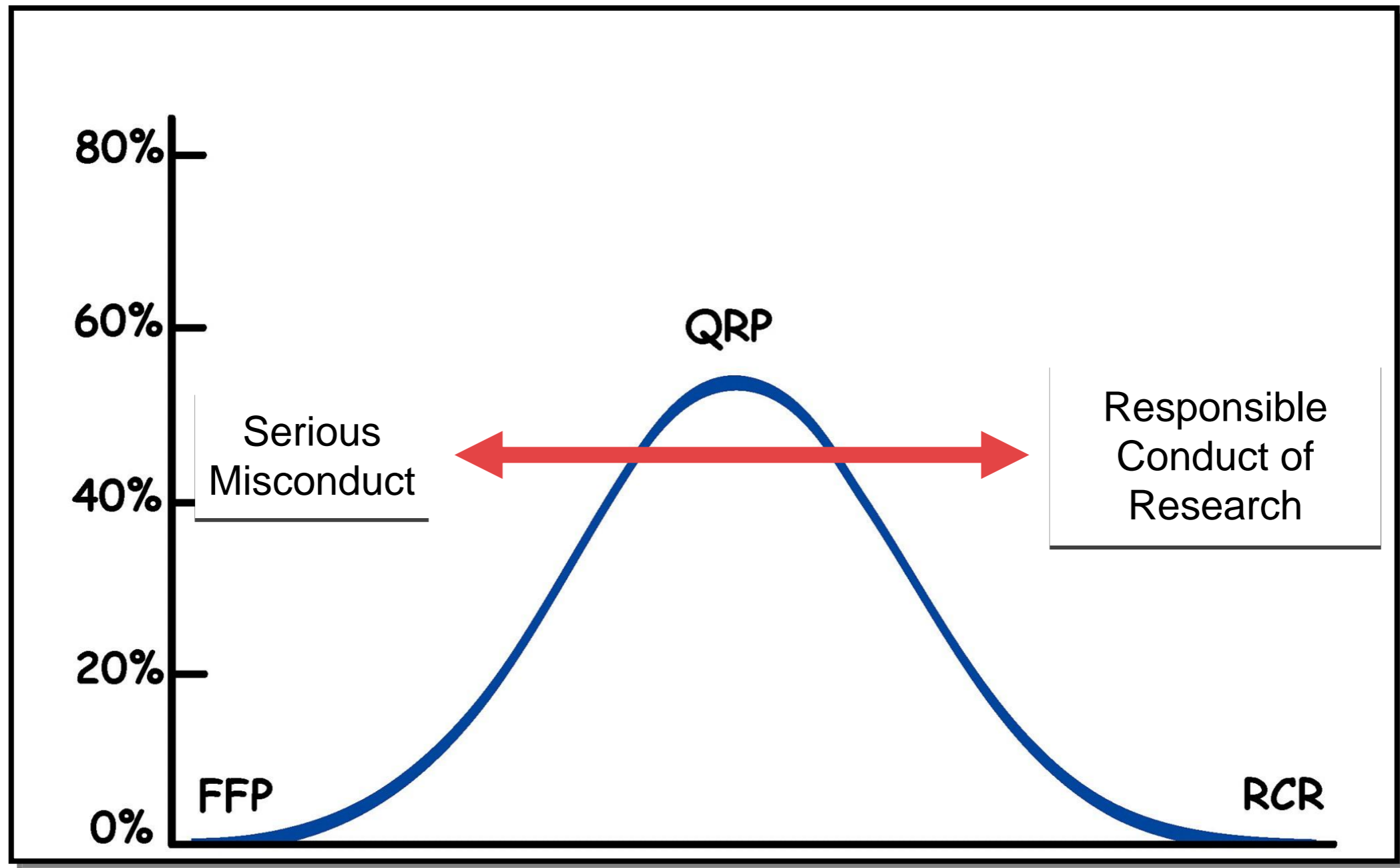

Q3. How have researchers responded?

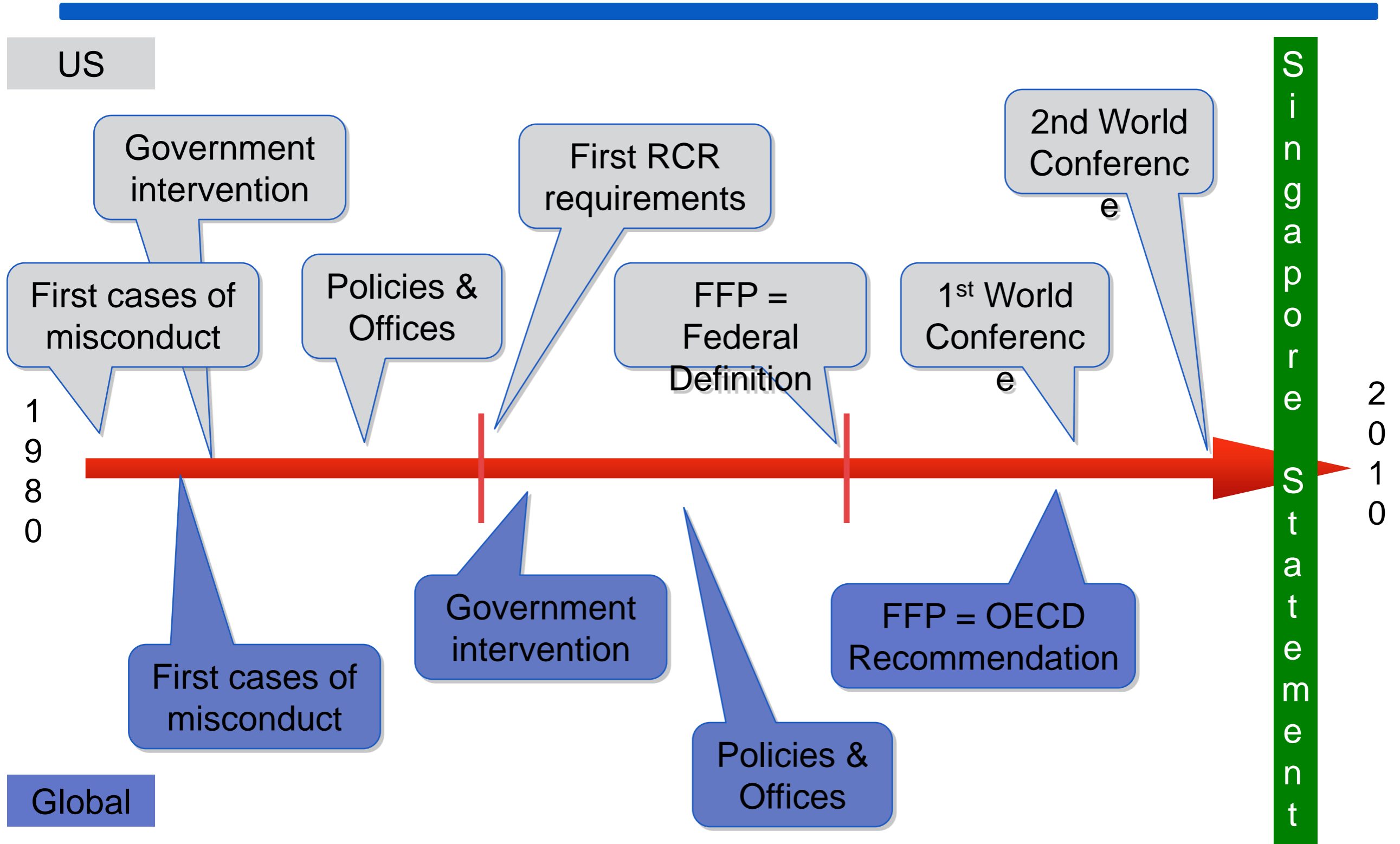

Policy paradox in the US.

Definition of misconduct narrowed

- ✓ Serious deviation from accepted practice ... to
- ✓ FFP that deviates from accepted practice

Evidence of scope of misconduct broadened

- ✓ 1980s, major cases dominated the news and policy making
- ✓ Today, other “questionable research practices” recognized

Changing definition of Misconduct

- 1986-Health and Human Services:
 - ✓ (1) **serious deviation**, such as fabrication, falsification, or plagiarism, **from accepted practices** in carrying out research or in reporting the results of research; or (2) ...
- 1987 National Science Foundation:
 - ✓ (1) fabrication, falsification, plagiarism, **or other serious deviation from accepted practices** in proposing, carrying out, or reporting results from research; (2) ...
- 2000 Office of Science and Technology Policy
 - ✓ Research misconduct is defined as fabrication, falsification, or plagiarism in proposing, performing, or reviewing research, or in reporting research results
 - ✓ **[must be a]** significant departure from accepted practices of the relevant research community

US Research Integrity System (government)

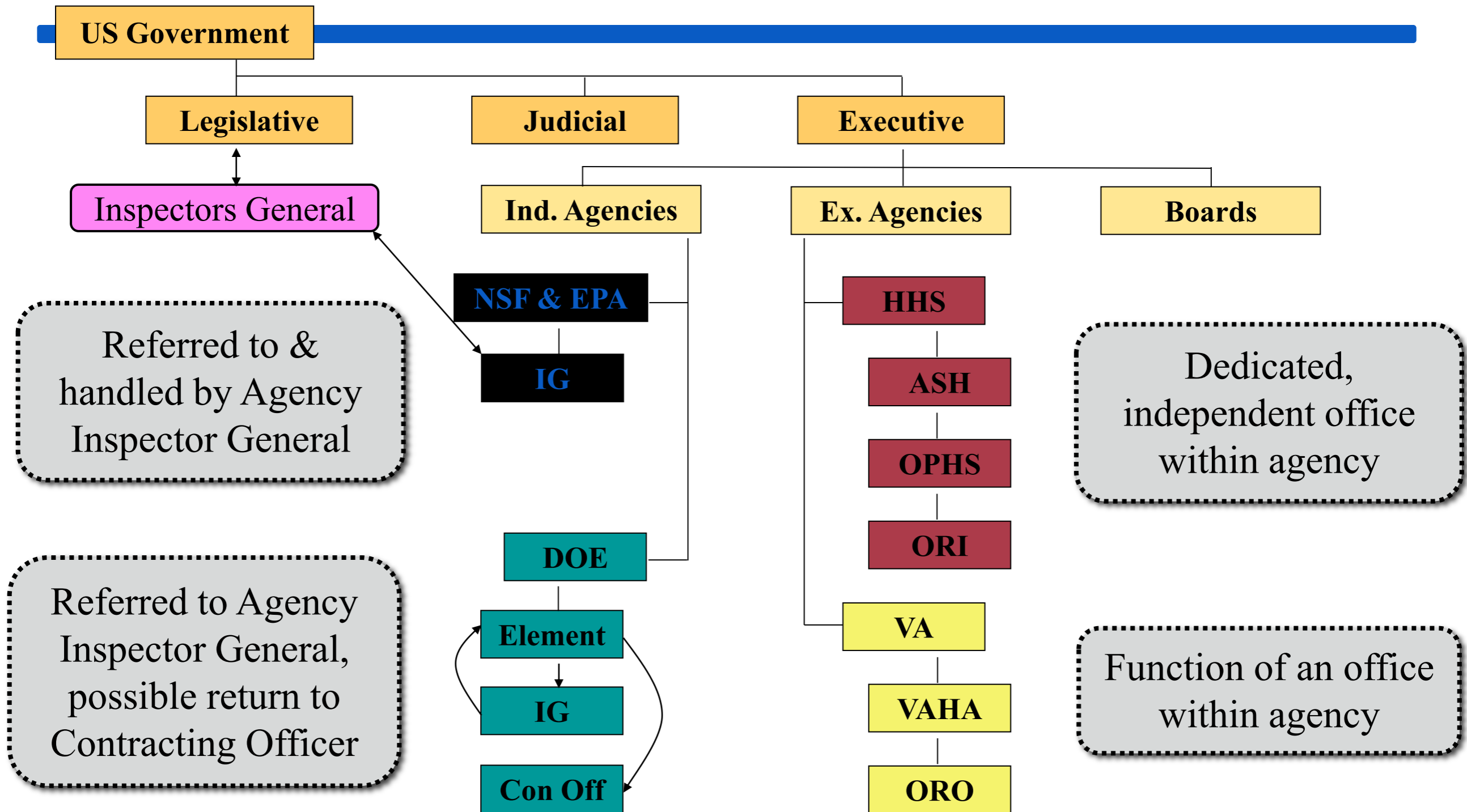

Q4. How should researchers and research institutions respond to misbehavior in research?

- Question: Who should take the lead
 - ✓ US, researchers took lead, failed
 - ✓ Government stepped in
- Current practice
 - ✓ Government sets policies
 - ✓ Institutions responsible for investigations & training
- Who should / will take the lead in Brazil?
 - ✓ Government
 - ✓ Institutions?
 - ✓ Industry?

Three elements of institutional program

① Rules and Best Practices:

- Misconduct, Human and animals subject research....
- Handbooks outlining best practices

② Training:

- On rules and best practices
- Ethics and critical thinking

③ Climate

- Clear rules sensibly enforced
- Fair, reasonable reward system
- Realistic demands

➤ An effective program requires all three

1. Rules and best practices

- Adopt research misconduct policy
- Essential elements”
 - ✓ A definition of misconduct
 - ✓ Procedures for receiving and responding to allegations that include:
 - Inquiry
 - Investigation
 - Adjudication
 - ✓ Protection of whistleblowers
- Should be fair, timely, and protect confidentiality

Other policies and best practices

- Partial list
 - ✓ Human and animal subject research
 - ✓ Responsible publication practices
 - ✓ Conflict of interest
 - ✓ Intellectual property
 - ✓ Mentoring, supervision, and grant management
 - ✓ Safety and other special concerns
 - ✓ Data storage and sharing
- Research institutions must clearly define and publicize their expectations.

Establishing a training program

➤ Four basic questions:



1. Reasons ~ why establish a program?
2. Audience ~ who are you trying to reach?
3. Objectives ~ what are you trying to accomplish?
4. Resources ~ what funds and people are available?

Models for RCR training in US

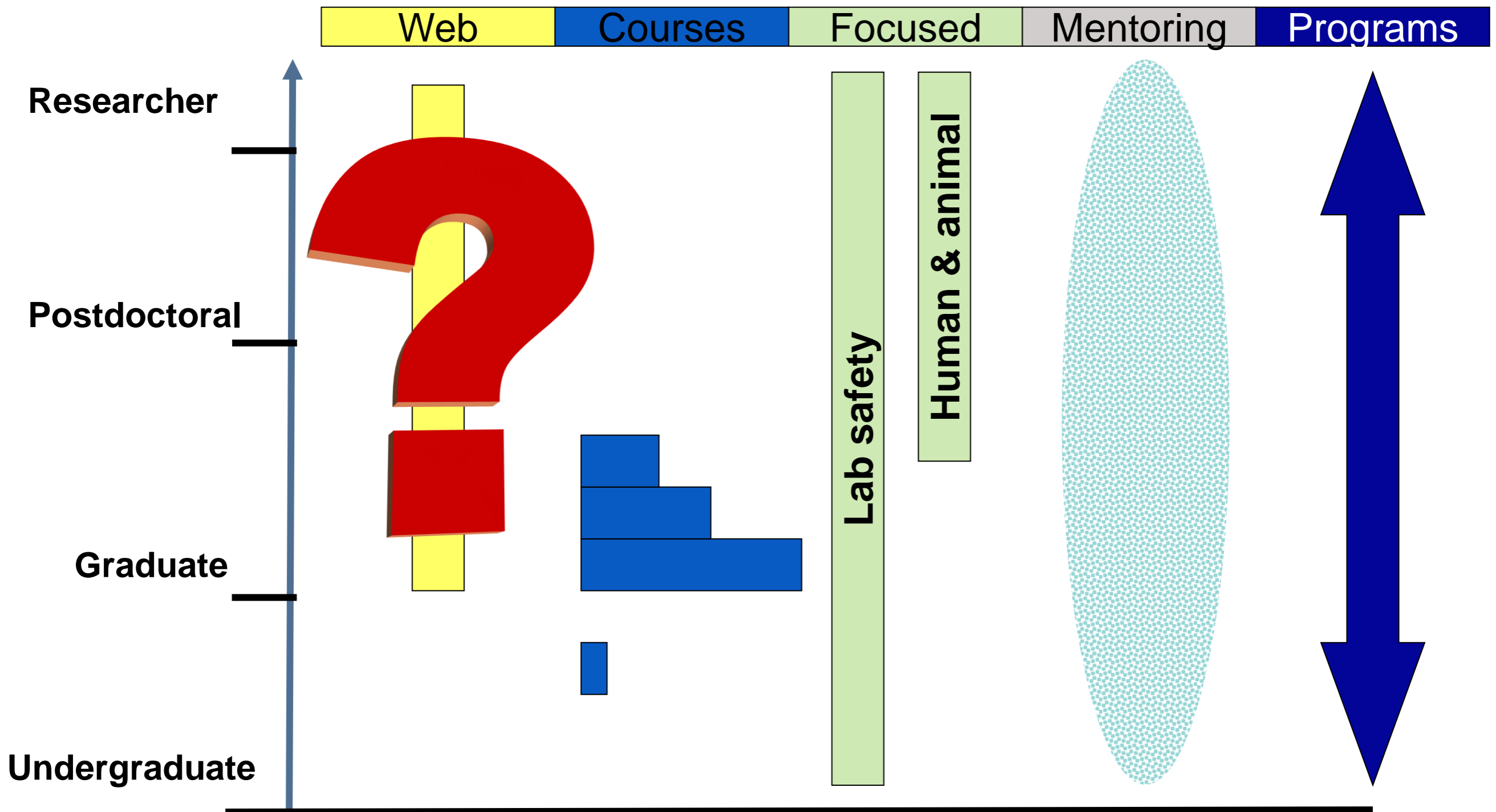

3. Climate

➤ Climate influences research behavior:

Norms	Counternorms
Share	Secret
Empirical	Personal
Advance science	Self-interest
Skeptical	Dogmatic

Adhering to Norms/CNs

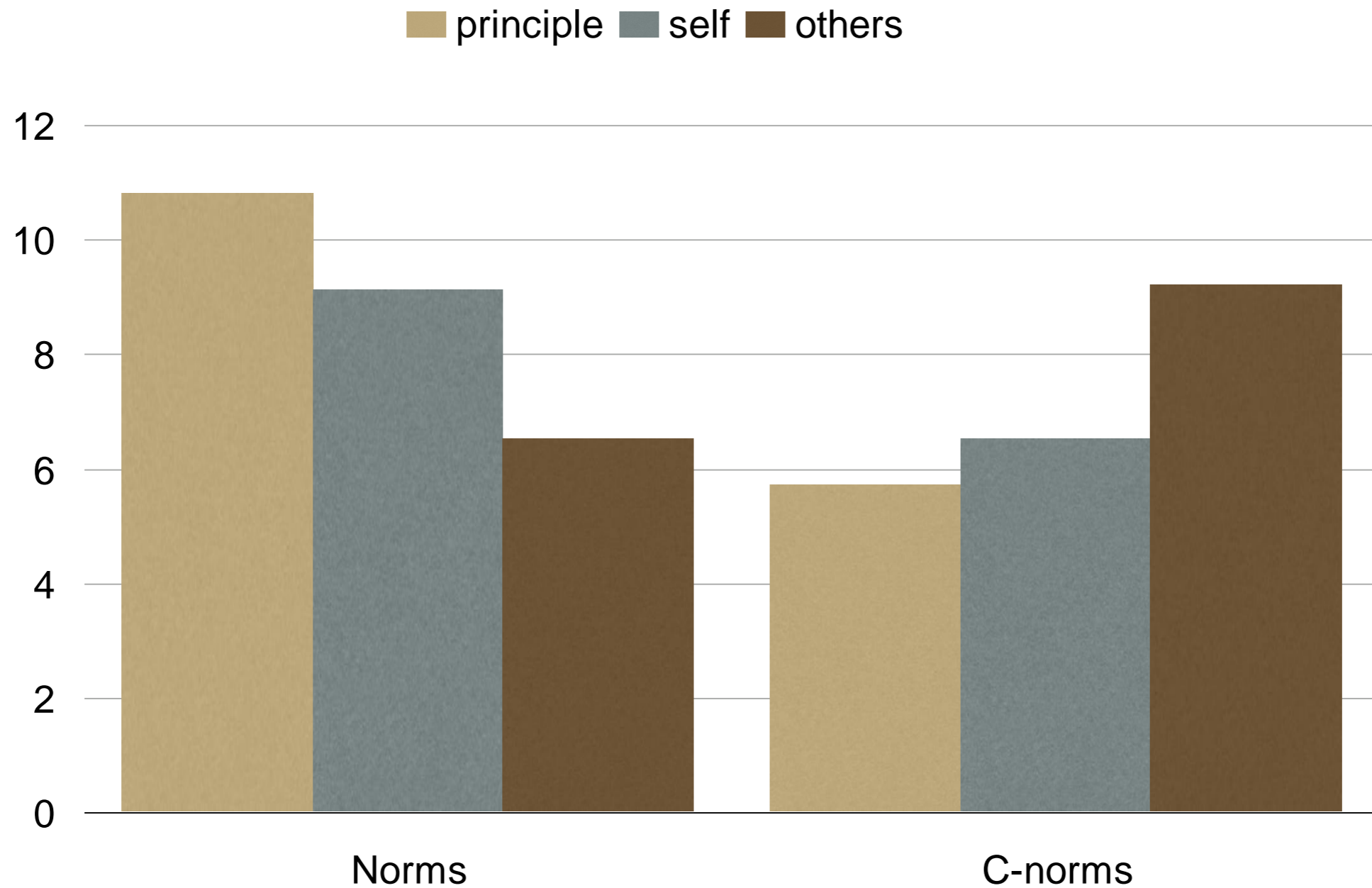

Implications



- How can every researcher be better than her/his colleagues?
- How will researchers behave if they feel they have more integrity than their colleagues?

➤ Integrity is everyone's responsibility, not someone else's!



Thanks - Obrigado

nsteneck@umich.ed

u

Q1. Reasons for RCR instruction?

- Main reason in US: required
 - ✓ Government funded trainees
 - ✓ Research with animals and humans
- Other reasons:
 - ✓ Good publicity
 - ✓ Raise awareness
 - ✓ Foster integrity
 - ✓ Prevent misconduct
- Even if not required, should be developed
 - ✓ Provide evidence of concern (good publicity)
 - ✓ If properly delivered, should raise awareness

Q2. Target audience?

- Three main audiences:
 - ✓ Students
 - Defined & controllable audience
 - Key point in career development
 - ✓ Researchers
 - Directly responsible for research projects
 - May be resistant to required instruction
 - ✓ All research staff and administrators
 - Play important roles in research, should be trained
 - Many career paths, difficult to identify and instruct
- Most RCR programs are for students

Q3. Objectives?

- Most common objectives:
 - ✓ Impart information
 - Policies & regulations
 - Codes of ethics
 - Best practices
 - ✓ Develop critical reasoning skills
 - Principle-based reasoning
 - Ways to recognize and resolve ethical dilemmas
 - ✓ Change behavior/enhance integrity
 - Recognize and change unprofessional behavior
 - Avoid practices that could lead to misconduct
- Evidence of effectiveness is weak

Q4. Resources?

- Commonly taught by unpaid volunteers
 - ✓ Seed funds for organization are helpful
 - ✓ Meals and other rewards provide incentives
- Additional resources
 - ✓ RCR coordinators becoming more common
 - ✓ Web designer if web-based
- Budgets vary widely, \$5-10K to \$1-2M/year
- Two important points:
 - ✓ good program can be expensive
 - ✓ poor program may have the opposite effect